

MCHG2 series

LOWER HEIGHT of THREE JAW GRIPPERS



Features:

- Bore Sizes ϕ 16, 25, 32, 40, 50, 63, 80, 100, 125 mm.
- Pinholes are incorporated as standard, facilitating accurate mounting which is achieved through either body tapped or through hole mounting.
- Auto switches can be simply attached via the standard built-in grooves.
- The 3-jaw gripper is designed in lower height with long stroke.

Order example:

MCHG2 – 16 – RT × 1

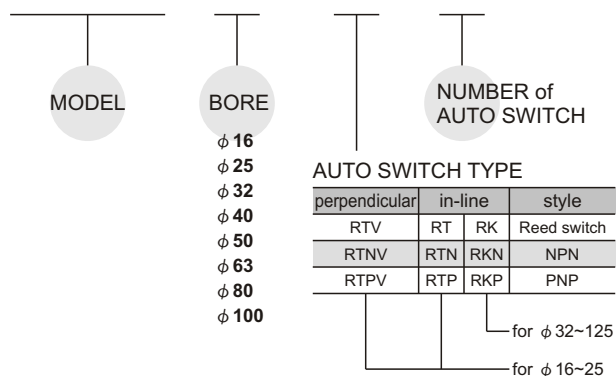

Specification:

Model	MCHG2-16D	MCHG2-25D	MCHG2-32D	MCHG2-40D	MCHG2-50D	MCHG2-63D	MCHG2-80D	MCHG2-100D	MCHG2-125D	
Acting type	Double acting									
Tube I.D. (mm)	16	25	32	40	50	63	80	100	125	
Stroke (mm)	4	6	8	8	12	16	20	24	32	
Medium	Air									
Operating pressure (kgf/cm ²)	2~6			1~6						
Ambient temperature	- 10~+60°C (No freezing)									
Repeatability	±0.01									
Max.operating frequency(c.p.m)	120		60			30				
Lubrication	Not required									
※Effective gripping force N(lbf) at (5kgf/cm ²)	External	14(3.1)	42(9.4)	74(16.6)	118(26.5)	187(42)	335(75)	500(112)	750(169)	1270(285)
	Internal	16(3.6)	47(10.6)	82(18.4)	130(29)	204(46)	359(81)	525(118)	780(175)	1320(297)
Weight(kg)	80	150	240	400	540	1020	1880	3300	6200	

※ Values for 16 to 25 are with gripping point L=20mm, for 32 to 63 with gripping point L=30mm, and for 80 to 125 with gripping point L=50mm, Refer to the "Effective Holding force" data on pages 5 through 6 for the gripping force at each gripping position.

- Open and closed diameter values apply for external gripping of work pieces.

Multiples of gripping force by work piece weight

Number of fingers: When $n=3$

If us performs calculations allowing for impacts which occur during normal transfer, etc., using a safely margin of $a=4$.

6.67 × work piece weight	13.33 × work piece weight
When $\mu = 0.2$ $F = (mg / (3 \times 0.2)) \times 4 = 6.67 \times mg$	When $\mu = 0.1$ $F = (mg / (3 \times 0.1)) \times 4 = 13.33 \times mg$

Note: Even in cases where the coefficient of friction is greater than $\mu = 0.2$, for safety reasons, we recommends selcting a gripping force which is at least 6.67 to 13.33 times the work piece weight.

It is necessary to allow a greter safety margin for hight accelerations and strong impacts, etc.

Effective Holding Force:

Holding Point

- Although the condition differs according to the coefficient of friction between the attachment and work, select a model that can produce a holding force of 10 to 20 times the work.
- Work should be held at a point within the range for a given pressure indicated in the effective holding force holding force table shown below.

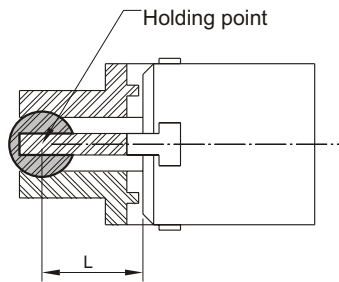

External hold

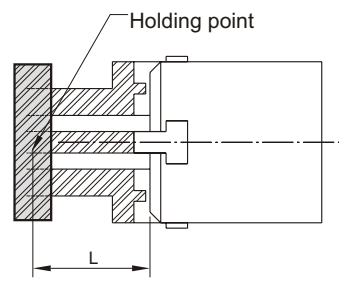

Internal hold

L: Holding point distan

Effective Holding Force

- Indication of effective holding force The holding force shown in the tables represents the holding force of one finger when all fingers and attachments are in contact with the work

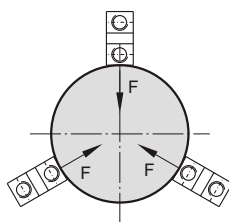

External hold

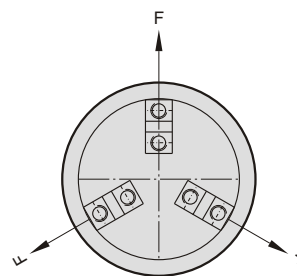

Internal hold
F: Thrust of one finger

Model Selection Illustration

When gripping a work piece as in the figure to the left, and with the following definitions.

n : Number of fingers

F : Gripping force (N)

μ : Coefficient of friction between the attachments and the work piece

m : Work piece mass (Kg)

g : Gravitational acceleration ($=9.8m/s^2$)

mg : Work piece weight (N)

The conditions under which the work piece will not drop are

$$n \times \mu F > mg$$

And therefore,

$$F > mg / (n \times \mu)$$

With "a" representing the extra margin, F is determined by the following formula:

$$F = a \times mg / (n \times \mu)$$

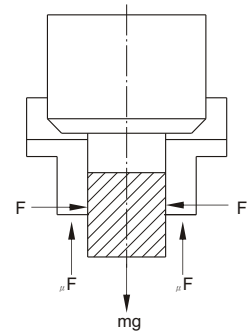

- When the work is held at a point outside of the recommended range for a give pressure, an excessive unbalanced load is applied to the finger sliding section, causing excessive play of the fingers and may cause premature failure.

External hold

Internal hold

External hold

Internal hold

MCHG2-16D

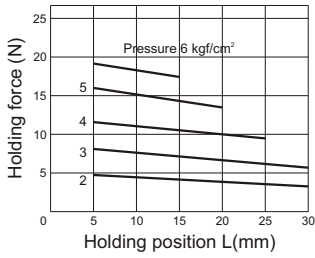

MCHG2-16D

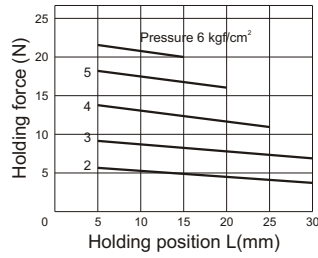

MCHG2-25D

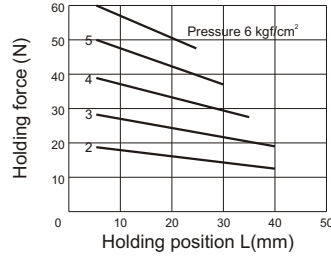

MCHG2-25D

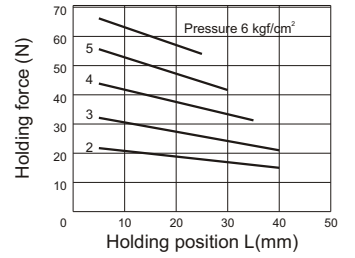

MCHG2-32D

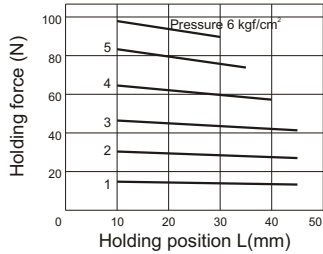

MCHG2-32D

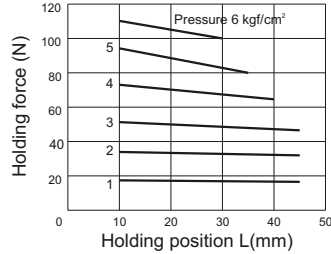

MCHG2-40D

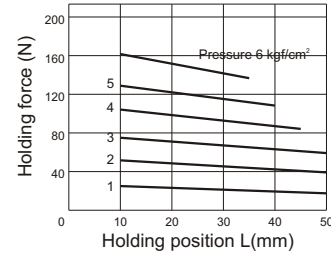

MCHG2-40D

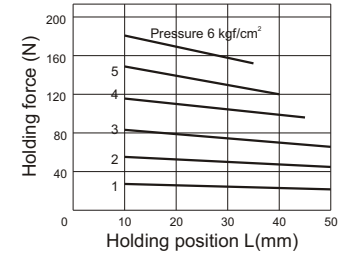

MCHG2-50D

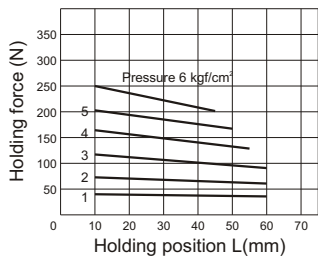

MCHG2-50D

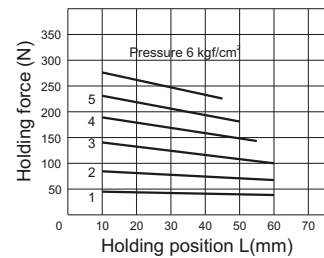

MCHG2-63D

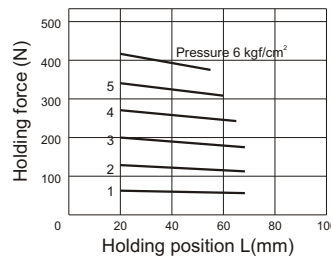

MCHG2-63D

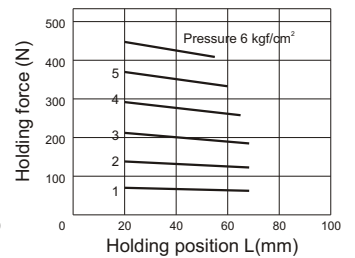

MCHG2-80D

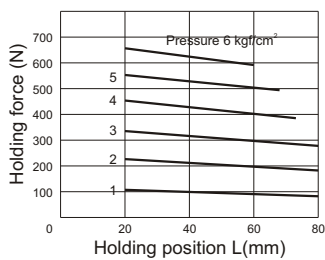

MCHG2-80D

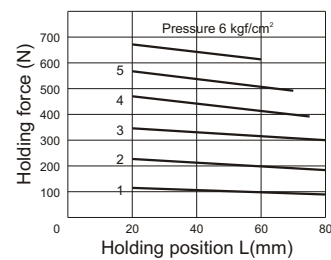

MCHG2-100D

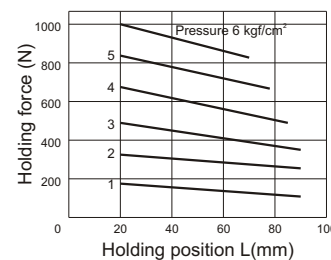

MCHG2-100D

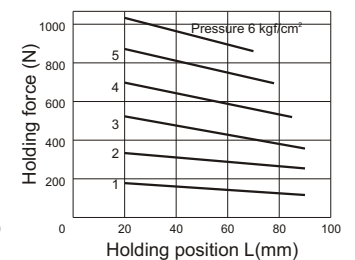

MCHG2-125D

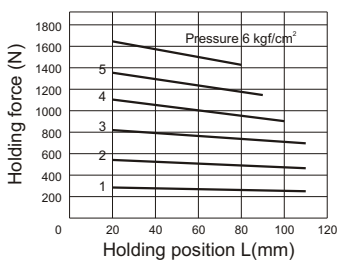

MCHG2-125D

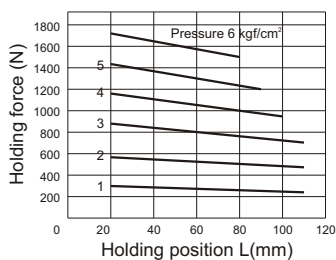

MCHG2 $\phi 16, \phi 25$

LOWER HEIGHT of THREE JAW GRIPPERS

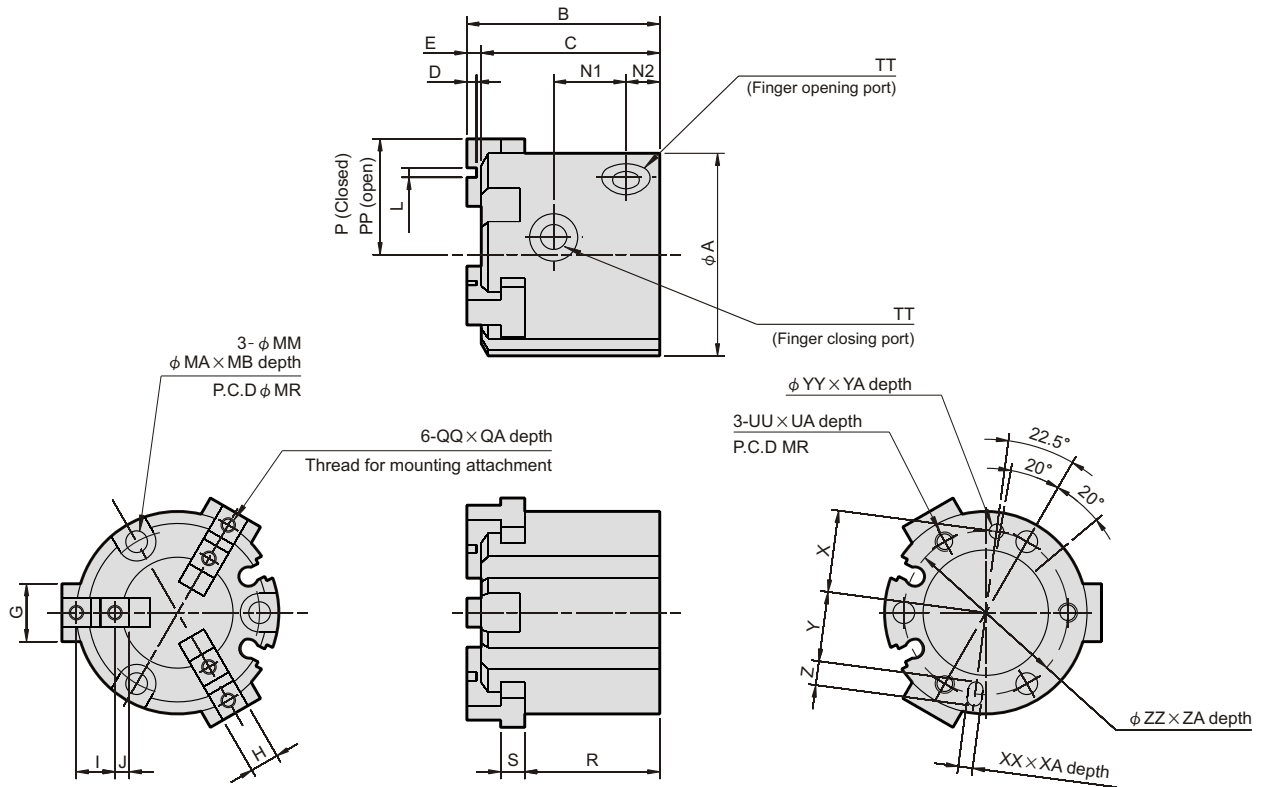

Auto switch mounting groove position

$\phi 16$

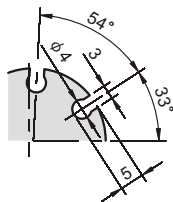

$\phi 25$

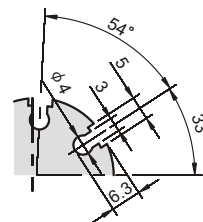

Code Tube I.D.	A	B	C	D	E	G	H	I	J	L	MA	MB	MM	MR	N1	N2	P	PP	QA	QQ	R	S	TT	UA
16	30	35	32	2	3	8	5h9 ⁺⁰ _{-0.030}	6	2	2H9 ^{+0.025} ₋₀	6.5	8	3.4	25	11	7	15	17.5	5	M3 \times 0.5	25	4	M3 \times 0.5	4.5
25	36	40	37	2	3	12	6h9 ⁺⁰ _{-0.036}	8	3	2H9 ^{+0.025} ₋₀	8	10	4.5	34	15	7	21	24	6	M3 \times 0.5	28	5	M5 \times 0.8	6

Code Tube I.D.	UU	X	XA	XX	Y	YY	Z	ZA	ZZ
16	M3 \times 0.5	12.5	2	2H9 ^{+0.025} ₋₀	11	2H9 ^{+0.025} ₋₀	3	1.5	17H9 ^{+0.043} ₋₀
25	M4 \times 0.7	17	3	2H9 ^{+0.025} ₋₀	14.5	3H9 ^{+0.025} ₋₀	5	1.5	26H9 ^{+0.052} ₋₀

MCHG2 $\phi 32 \sim \phi 80$

LOWER HEIGHT of THREE JAW GRIPPERS

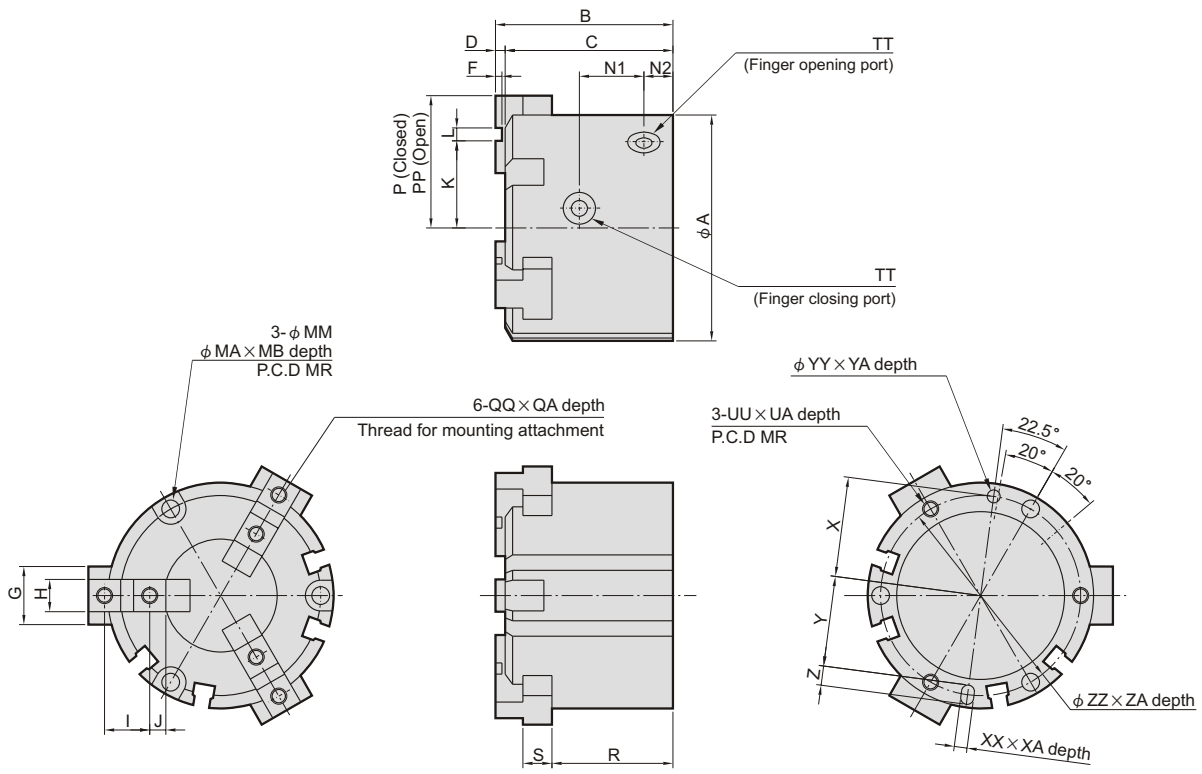

Auto switch mounting groove position

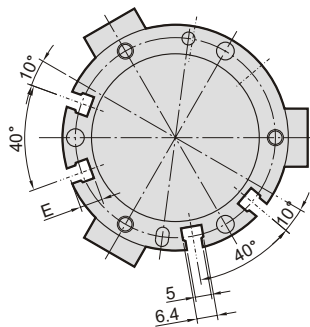

Code Tube I.D.	A	B	C	D	E	F	G	H	I	J	K	L	MA	MB	MM	MR	N1	N2	P	PP	QA	QQ	R	S	TT
32	52	44	41	3	6	2	14	8h9 ⁺⁰ _{-0.036}	11	4.5	21	2H9 ^{+0.025} ₋₀	8	9	4.5	44	16	8	28	32	8	M4×0.7	30.5	6	M5×0.8
40	62	47	44	3	8	2	16	8h9 ⁺⁰ _{-0.036}	12	4.5	23	3H9 ^{+0.030} ₋₀	9.5	9	5.5	53	17	9	31	35	8	M4×0.7	32	7	M5×0.8
50	70	55	52	3	7	2	18	10h9 ⁺⁰ _{-0.043}	14	5	27	4H9 ^{+0.030} ₋₀	9.5	12	5.5	62	20	9	35	41	10	M5×0.8	37.5	9	M5×0.8
63	86	66	62	4	7.5	3	24	12h9 ⁺⁰ _{-0.043}	17	5.5	34	6H9 ^{+0.036} ₋₀	11	14	6.6	76	22	12	43	51	10	M5×0.8	44	11	M5×0.8
80	106	82	77	5	9	4	28	14h9 ⁺⁰ _{-0.043}	20	6	44	8H9 ^{+0.036} ₋₀	11	19	6.6	95	27	13.5	53.5	63.5	12	M6×1	56	12	Rc1/8

Code Tube I.D.	UA	UU	X	XA	XX	Y	YY	Z	ZA	ZZ
32	6	M4×0.7	22	3	3H9 ^{+0.030} ₋₀	19.5	3H9 ^{+0.030} ₋₀	5	2	34H9 ^{+0.062} ₋₀
40	7.5	M5×0.8	26.5	4	4H9 ^{+0.030} ₋₀	23.5	4H9 ^{+0.030} ₋₀	6	2	42H9 ^{+0.062} ₋₀
50	10	M5×0.8	31	4	4H9 ^{+0.030} ₋₀	28	4H9 ^{+0.030} ₋₀	6	2	52H9 ^{+0.074} ₋₀
63	9	M6×1	38	5	5H9 ^{+0.030} ₋₀	34.5	5H9 ^{+0.030} ₋₀	7	2.5	65H9 ^{+0.074} ₋₀
80	12	M6×1	47.5	6	6H9 ^{+0.036} ₋₀	43.5	6H9 ^{+0.036} ₋₀	8	3	82H9 ^{+0.087} ₋₀

MCHG2 $\phi 100, \phi 125$

LOWER HEIGHT of THREE JAW GRIPPERS

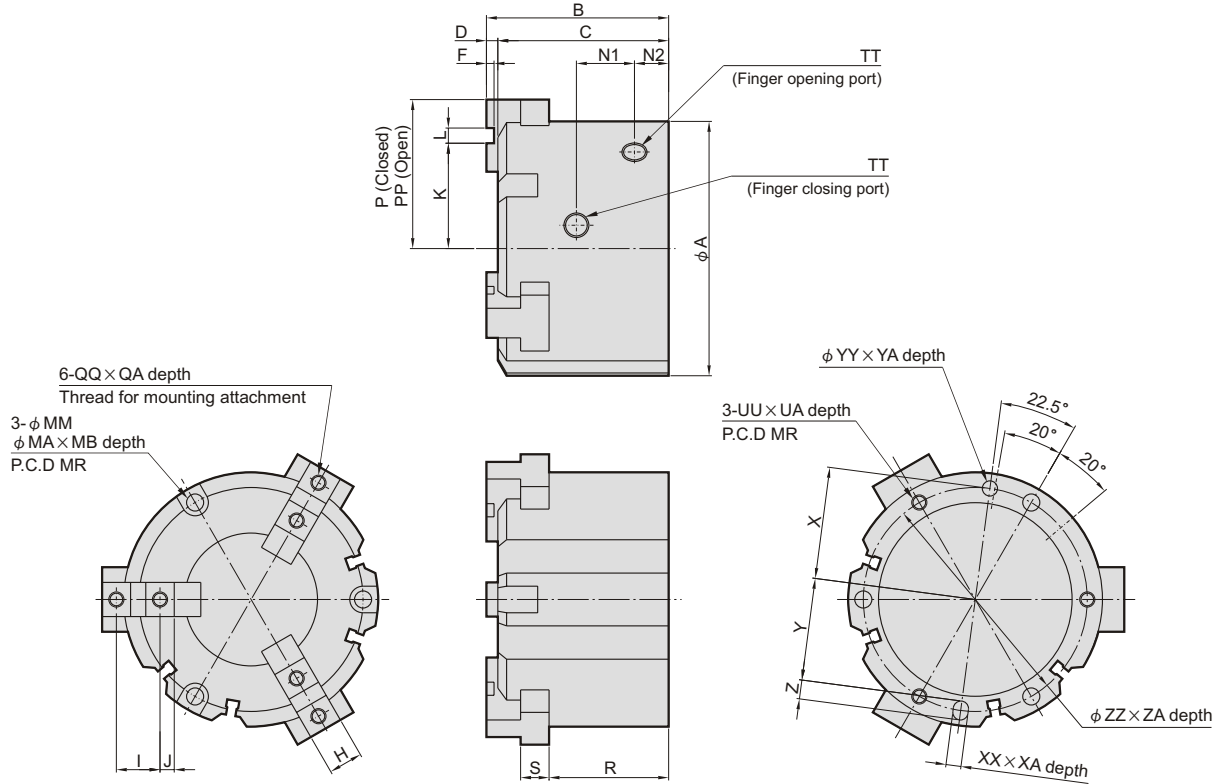

Auto switch mounting groove position (4 places)

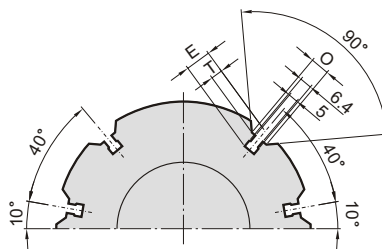

Code Tube I.D.	A	B	C	D	E	F	G	H	I	J	K	L	MA	MB	MM	MR	N1	N2	P	PP	QA	QQ	R	S	T
100	134	96	90	6	13	4	34	18h9 ⁺⁰ _{-0.052}	23	7.5	42.5	8H9 ^{+0.036} ₋₀	14	21	9	118	30.6	18	66	78	16	M8 \times 1.25	63	15	5
125	166	122	114	8	15	6	40	22h9 ⁺⁰ _{-0.052}	31	10.5	50	10H9 ^{+0.043} ₋₀	17.5	34	11	148	38	23.5	82	98	20	M10 \times 1.5	84	18	7

Code Tube I.D.	TT	UA	UU	X	XA	XX	Y	YA	YY	Z	ZA	ZZ
100	Rc1/4	16	M8 \times 1.25	59	6	8H9 ^{+0.036} ₋₀	54	6	8H9 ^{+0.036} ₋₀	10	4	102H9 ^{+0.087} ₋₀
125	Rc3/8	20	M10 \times 1.5	74	8	10H9 ^{+0.043} ₋₀	68	8	10H9 ^{+0.043} ₋₀	12	6	130H9 ^{+0.100} ₋₀